

Development of single-crystal CVD diamond detector for time-of-flight measurements

Y. Sato,^{*1} T. Shimaoka,^{*2} M. Kobayashi,^{*3} M. Takaki,^{*3} H. Miya,^{*3} M. Matsushita,^{*3} S. Michimasa,^{*3} K. Yako,^{*3}
S. Shimoura,^{*3} M. Tsubota,^{*2} J. H. Kaneko,^{*2} H. Murakami,^{*1} H. Sato,^{*1} K. Yoshida,^{*1} T. Kubo^{*1}

Production and identification techniques for radioactive isotope (RI) beams are important for nuclear physics experiments involving exotic nuclei that are very unstable. RI beams are generally produced as secondary beams from high-energy heavy-ion reactions using in-flight fragment separators. In these devices, a charged-particle detector with a fast response and high radiation hardness is required to measure the time of flight (TOF) of ions for identifying the RI beams in high-dose environments.

Diamond is one of the most promising materials for fabricating a charged-particle detector for performing accurate timing measurements under high-intensity beam conditions. Fast signals for superior timing resolution can be obtained because of the high breakdown electrical field strength and high carrier saturation velocities of the diamond crystal. Additionally, high radiation hardness to large charged-particle fluxes can be expected because of the higher displacement energy of diamond.

In this study, we fabricated a single-crystal (sc) chemical-vapor-deposited (CVD) diamond detector and evaluated the intrinsic timing resolution of the detector. Figure 1 shows the block diagram of the electronic circuit used for evaluating the timing resolution. Two diamond detectors were placed in the E7/B beam line at the RIKEN accelerator facility. The detectors were fabricated using an sc-diamond of approximately 4×4 mm². In brief, the detector has a layer structure of Pt/sc-diamond/Ti/Au. The thickness of the diamond crystals are 90 μ m and 139 μ m for the front-side and rear-side of the detector, respectively.

8.6 MeV/nucleon-⁷Li beams penetrated two diamond detectors. The pulses induced from the detector were read out using a broadband amplifier with an analog bandwidth of 1 MHz–2 GHz (CIVIDEC C2 Broadband Amplifier). The amplifier signals were processed with a leading edge discriminator, a time-to-amplitude-converter (TAC), and 8 k-multi-channel analyzer (MCA) for TOF measurement. The timing resolution of the measurement system was estimated to be 7.8 ps (σ) using a constant time difference generated by the fast-pulsar signal and cables.

Figure 2 shows the measured TOF spectrum. The width of the peak was estimated to be 45 ps (σ). The intrinsic timing resolution of the detector was evaluated by dividing the width of the peak by $\sqrt{2}$ and subtracting the timing resolution of the measurement system. Here, the same performance of the two detectors was assumed. The intrinsic timing resolution was estimated to be 31 ps (σ).

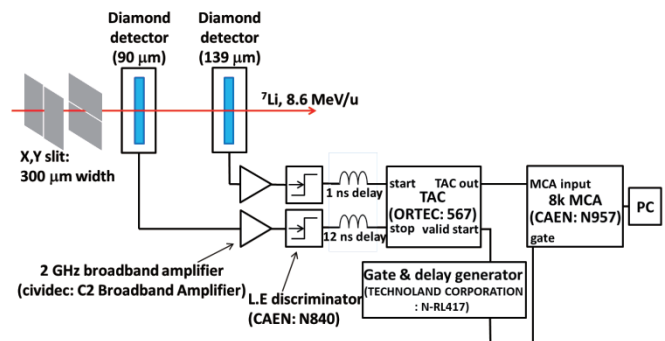

Fig. 1: Block diagram of the electronic circuit used in the TOF measurement. The start signal and stop signal were created by output signals from the rear-side and the front-side detector, respectively. The bias supply is left out. The time offset of ~ 11 ns was created using cables. L.E. discriminator: leading edge discriminator, TAC: time-to-amplitude-converter, MCA: multi-channel analyzer

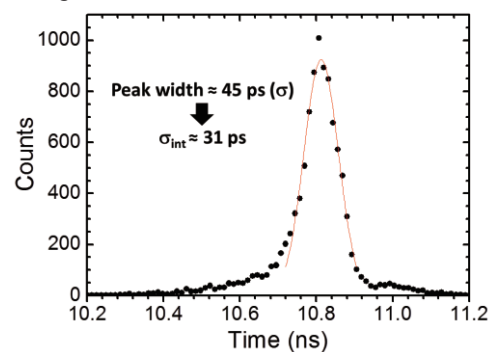

Fig. 2: Time of flight spectrum between two diamond detectors. The intrinsic timing resolution (σ_{int}) was evaluated using distribution of the peak (45 ps (σ)) and the timing resolution of the measurement system (7.8 ps (σ)).

This value is superior to the values reported by GSI: 57 ps and 39 ps for 600 MeV/nucleon-⁵⁸Ni and 1 GeV/nucleon-²³⁸U, respectively^{1,2}). On the other hand, NSCL/MSU achieved a resolution of ~ 15 ps for 87 MeV/nucleon-⁷⁸Kr³).

In a future study, we will attempt to fabricate a charged-particle detector using a higher quality sc-diamond and evaluate the intrinsic timing resolution. On the other hand, the use of a large size sc-CVD diamond (20 mm \times 20 mm) was considered to fabricate the process for manufacturing, large size detector.

References

- 1) E. Berdermann, et al.: Nuclear Physics B **78**, 533 (1999).
- 2) E. Berdermann, et al.: XXXVI Int. Winter Meeting on Nucl. Physics, Bormio 1998.
- 3) A. Stolz, et al.: Diam. Relat. Mater., **15**, 807 (2006).

*1 RIKEN Nishina Center

*2 Graduate School of Engineering, Hokkaido University

*3 Center for Nuclear Study, University of Tokyo